

RAIL WEB ELECTRICAL CONNECTION SYSTEM FOR RETURN TRACTION AND GROUNDING APPLICATIONS

AR 60D



Screw with (1 Piece) hollow hex head

Copper bush

Flat steel washer

Self-locking nut

Lug

Electrical Permanent Contact for rail web type AR 60D for hole diameter 3/4"

Railweb thickness: between 17/32" to 11/16".

This system has been studied, projected and realized by Cembre in 1988 after a deep analysis of existing electrical connection systems and their performances. The aim of the Cembre system is to provide a general and substantial improvement on the most important characteristics of a contact between the rail and the electric cables like:

- extremely low resistance (in terms of micro-ohms);
- easy installation procedures and not depending on operator skillness;
- short installation time (less than one minute for each operation);
- possibility of disconnection / connection of attached cables.
- cold extruded (requires no heating to the rail).

After extensive tests, either in laboratory or in the field, the system has been recognized as totally reliable and perfectly matching the above listed requirements.

System components are as follows:

- a** - Electrolytically tin-plated copper bush type AR 60-1
- b** - Steel M12 screw with hollow hex head (1 piece)
- c** - Flat steel washer
- d** - Self-locking nut

To be installed by:

Hydraulic tool type HTEPE-DETY or tool type RHTEP

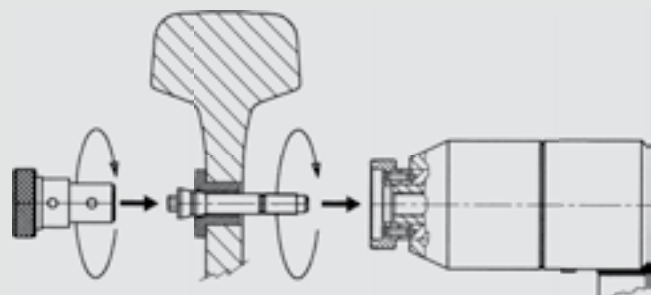
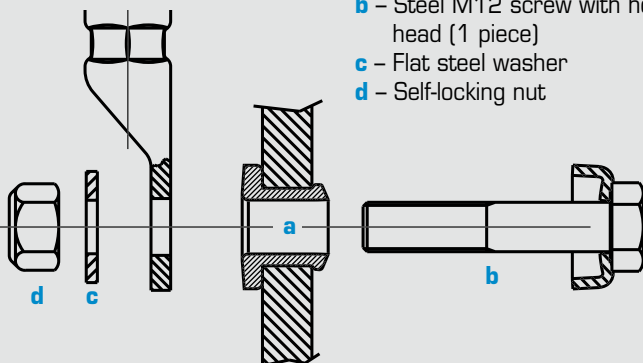

AR 60D ASSEMBLY

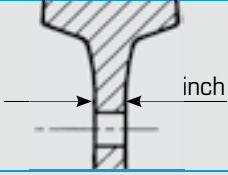
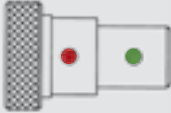
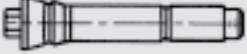
		\varnothing inch		
AR 60D	$17/32" \div 11/16"$	$3/4"$	CAL 19.20	OG 13.2

1

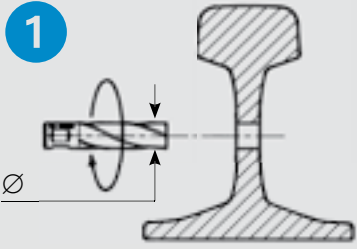

2

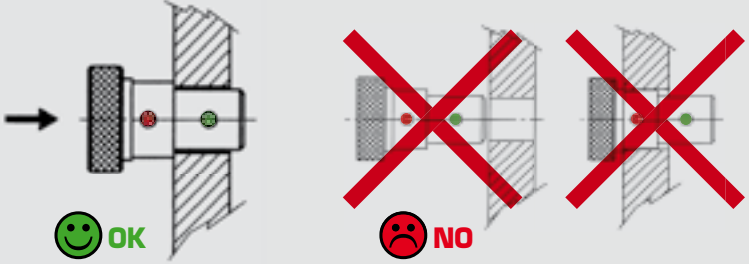

3

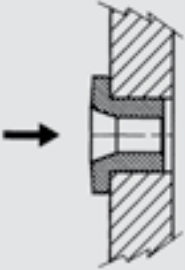

4

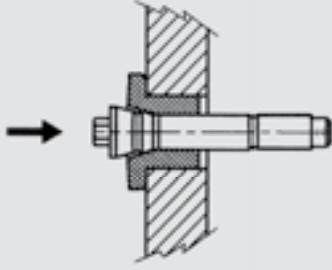

5

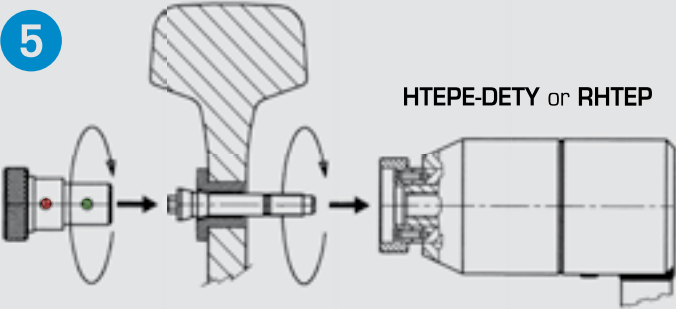

HTEPE-DETY or RHTEP

6

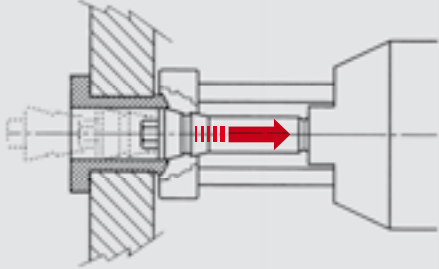

7

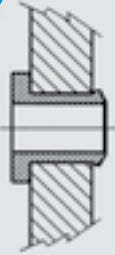

8

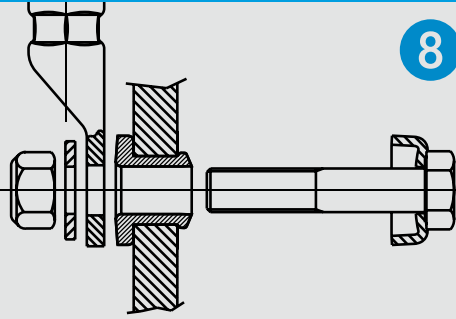

9

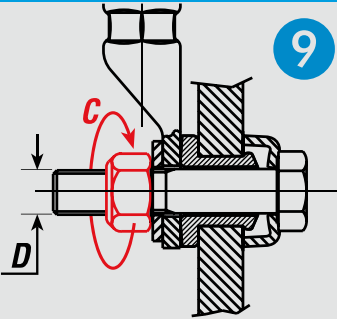

D	Lug	Torque	
		lb ft	Nm
M12	Cu	59	80
	Al	37	50

RAIL WEB ELECTRICAL CONNECTION SYSTEM FOR SIGNALLING DEVICES

AR 69D



Steel M6
screw with (1 Piece)
hollow hex head



Flat steel
washer



Lug

Copper bush



M6 Self-
locking nut

Electrical Permanent Contact for rail web type AR 69D, for hole diameter 3/8"

Railweb thickness: between 17/32" to 11/16"

System components are as follows:



- a** - Copper bush type AR 69D-1 protected on surface by suitable metal plating
- b** - Steel M6 screw with hollow hex head
- c** - Flat steel washer
- d** - M6 self-locking nut

To be installed by:

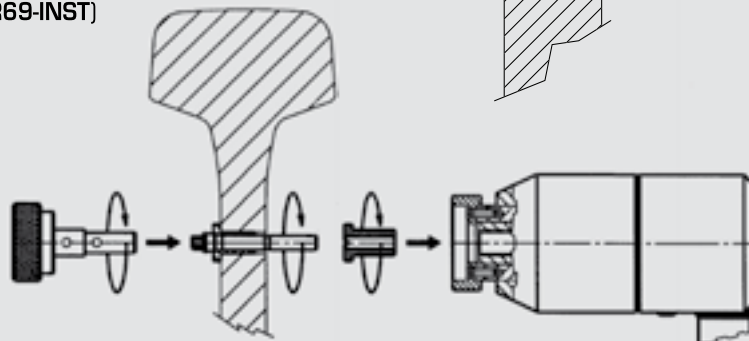
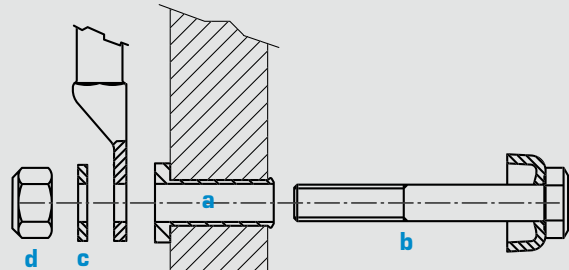
Hydraulic Tool type HTEPE-DETY
or RHTEP (using installation kit type AR69-INST)
or hand held ratchet tool Type MTE1

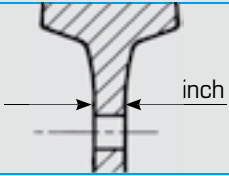
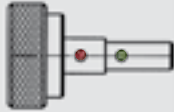

AR 69D ASSEMBLY

		\varnothing inch			
AR 69D	$17/32" \div 11/16"$	3/8"	CAL 95.10	OG 6.5	M9M5

1

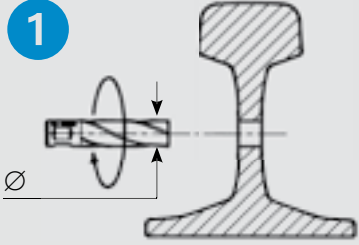

2

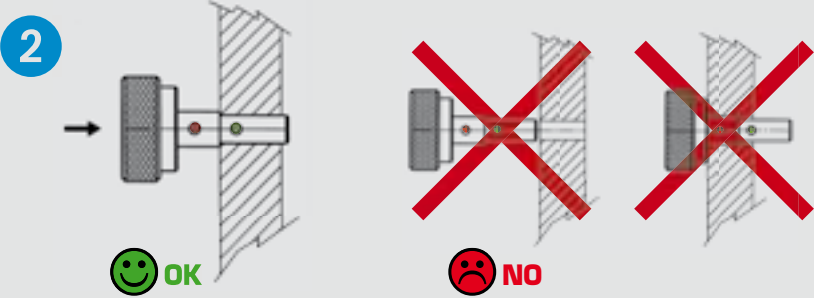

3

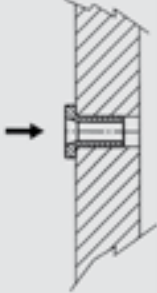

4

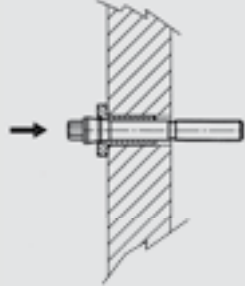

5

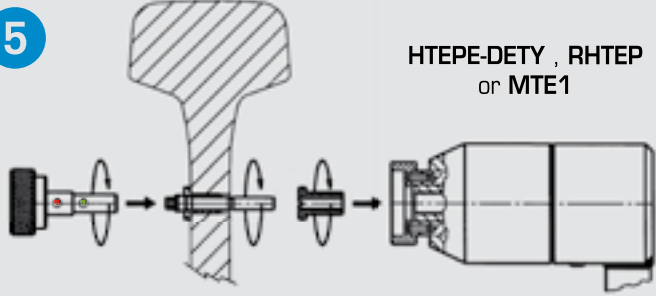

HTEPE-DETY , RHTEP
or MTE1

6

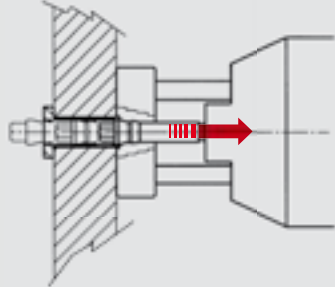

7



8

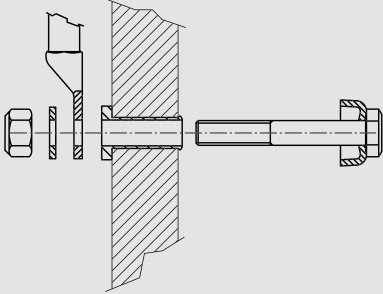

9

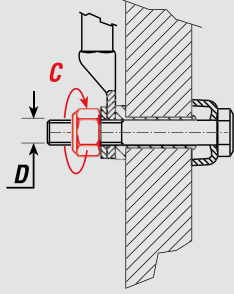

D	Lug	Torque	
		lb ft	Nm
M6	Cu	7.4	10
	Al	4.8	6.5

RAIL WEB CABLE CONNECTION SYSTEM DOUBLE CONTACT BUSH TYPE

AR 260D AR 280*

*AR 280 with
copper lug 2A48-M14
approved by
NEW YORK CITY
TRANSIT AUTHORITY



Electrolytically
tin-plated
copper bush

Cable lugs

Stainless
steel Bolt

Stainless steel
self-lock nut

Electrolytically
tin plated
copper alloy washer

Stainless steel
flat washers

System components are as follows:

AR 260D

- a - Electrolytically tin-plated copper bush type AR 260-1
- b - Electrolytically tin-plated copper alloy washer type AR 260-2
- c - M12x70 flat steel bolt
- d - M12 stainless steel flat washer
- e - M12 stainless steel self-lock nut

AR 280

- a - Electrolytically tin-plated copper bush type AR 280-1
- b - Electrolytically tin-plated copper alloy washer type AR 280-2
- c - M14x70 flat steel bolt
- d - M14 stainless steel flat washer
- e - M14 stainless steel self-lock nut

To be installed by:

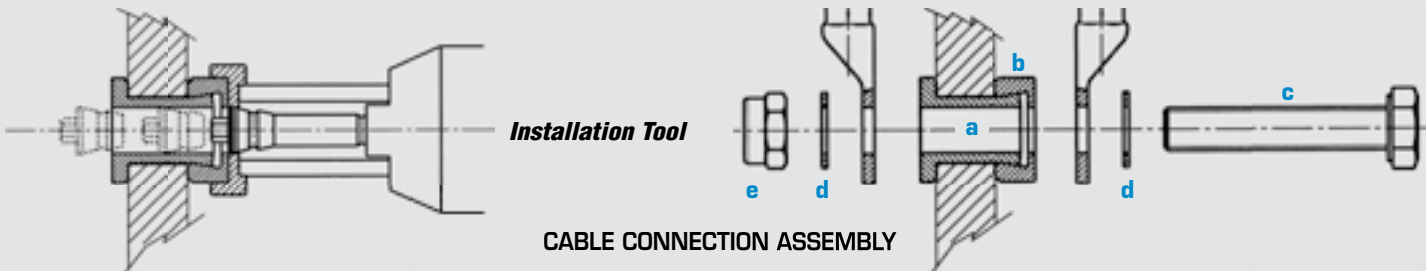

hydraulic tool type HTEPE-DETY or RHTEP for AR 260D (HTEPY for AR 280)



RAIL WEB CABLE CONNECTION APPLICATIONS

- Traction return bonding • Continuity bonding
- Signal track circuit connection • Ground bonding

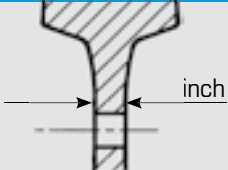
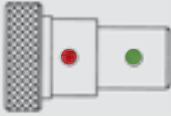
AR 260D and AR 280 ASSEMBLY

		\varnothing inch		
AR 260D	$17/32" \div 11/16"$	$3/4"$	CAL 19.20	OG 13.2
AR 280	$9/16" \div 5/8"$	$1\ 1/8"$	CAL 118.1532	OG 15.2

1

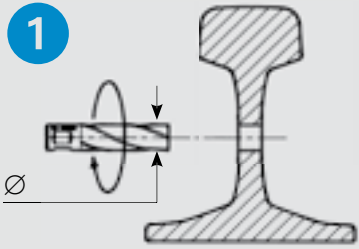

2

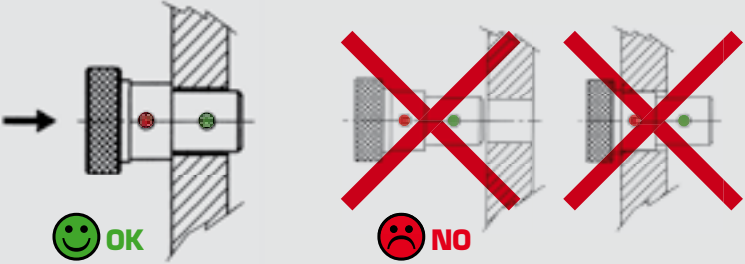

3

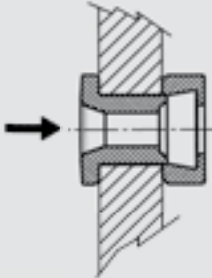

4

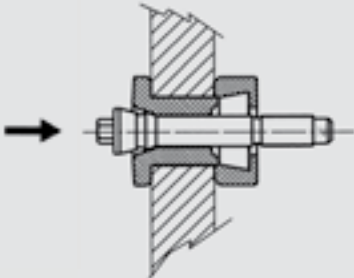

5

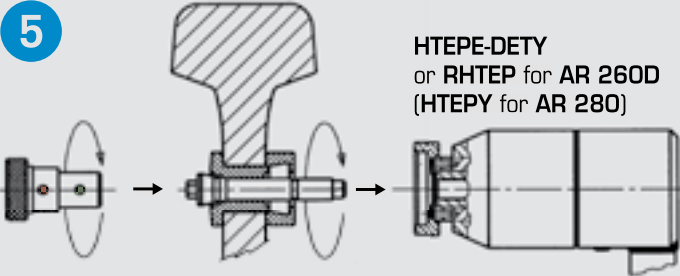

HTEPE-DETY
or RHTEP for AR 260D
(HTEPY for AR 280)

6

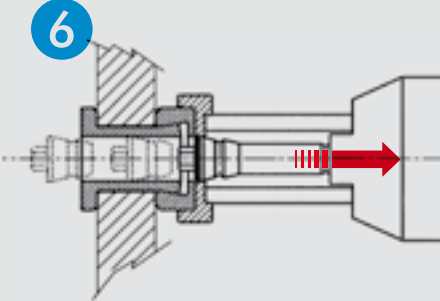

7



8

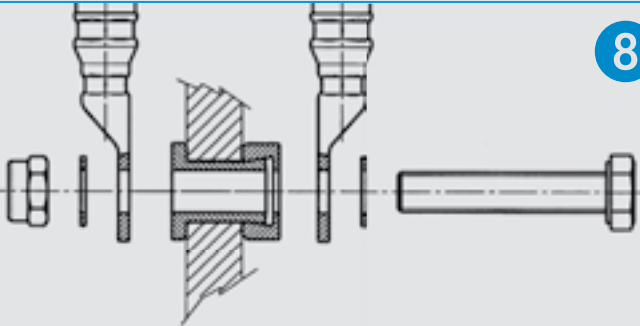

9

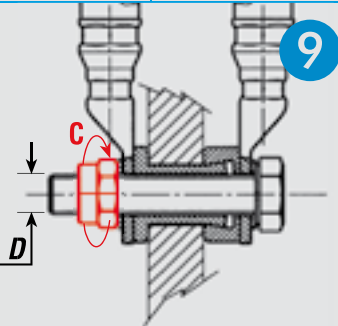

	D	Torque	Torque	
			lb ft	Nm
AR 260D	M12	Cu	59	80
		Al	37	50
AR 280	M14	Cu	88	120
		Al	55	75

RAIL WEB ELECTRICAL CONNECTION SYSTEM TYP AR

The advantages of using the Cembre rail web contacts are that the bush can be installed in all weather and environmental conditions, with a simple, easy to operate portable tool, producing a consistent, quality installation, independent from the skill of the operator. The reduced installation time of this system results in overall cost savings.

During installation the bush is 'extruded' and the copper material flows into the wall of the hole, compensating for variation in hole size and filling any voids and uneven surfaces.



Schematic view of the extrusion process (section)



Extensive testing, performed in the test laboratory and in the field, have demonstrated a low and constant resistance, mechanical stability and protection from atmospheric corrosion.

Examples of the electrical tests



Heat Cycling Tests



Short Circuit Testing



On site testing

Examples of tests in salt water environments



Salt Mist Exposure Testing



TYPICAL APPLICATIONS

● AR60D installation



Transmission of coded and return current on lines fitted with automatic block

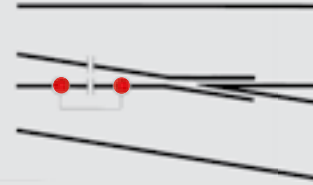

Signalling and traction current connection to manganese steel cast exchange units

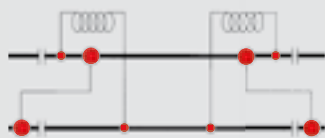
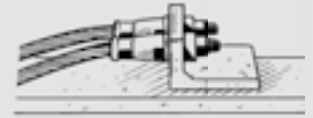

Various connections involved in the train location system



Return current connections to substations

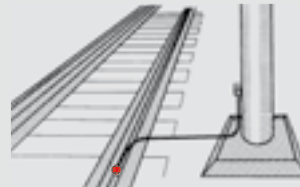

Connections of metallic structures to rails for grounding purpose

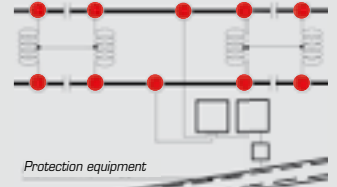

Protection equipment

Electrical connection of underground metal structures to rails



Examples of lines equipped with automatic block.

Cembre Inc is member of Remsa, RSSI, Arema association.



Examples of AR60D system in electric joint applications.



Features, and advantages of this system are explained in various railways magazines

The AR60D system is used world wide proving to be fully reliable in all the working conditions.

ELECTRICAL CONNECTION SYSTEMS TO RAILS AND TO TRACK EQUIPMENT



1) Example of electrical connections using a low stranded conductor to provide electrical continuity on cast manganese steel crossovers.

1a) **AR60D** rail web connection, rail side

2) Example of electrical connections using a flexible cable to provide electrical continuity on cast manganese steel crossovers.

2a) **AR60D** rail web connection, rail side

3) **AR260D** double contact rail web connection

