

# SUPPORT TROLLEY

conforming to  
**EN13977**  
conforming to

## CS-SD CS-SD-TA

### CS-SD-E (with braked wheels)\*

The support mechanism, which secures the portable drilling machines SD-9P-ECO, SD-10E and the portable impact wrench NR-11P, incorporates a gas pressure spring to give a constant, balanced control to the machine during operation. Fitted with insulated wheels, the trolley does not interfere with the track electrical circuits. The trolley is easily closed and can comfortably be carried by a single operator. The **CS-SD** standard version is suitable to work on standard gauge rails (1.435 mm), while the **CS-SD-TA** is the adjustable version suitable to cover gauges from 1.000 to 1.700 mm.

*\*All configurations meet the stability requirements of sect. 5.15 EN 13977:2005 + A1:2007.*



The trolley is easily assembled and can comfortably be carried by a single operator.



### General features:

- **Weight:** drill support unit 17,5 kg
- **Bar with 3rd wheel:** 12 kg

- **Dimensions (mm):**

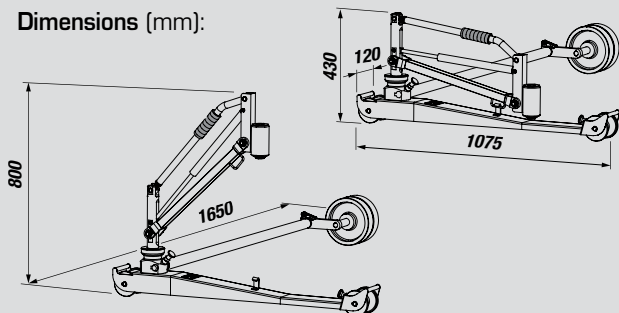

## Portable drilling machines for wooden sleepers SD-9P-ECO + support trolley CS-SD

(See Page 33)



## Portable petrol engine impact wrench NR-11P + support trolley CS-SD

(See Page 29)

